

North Creek

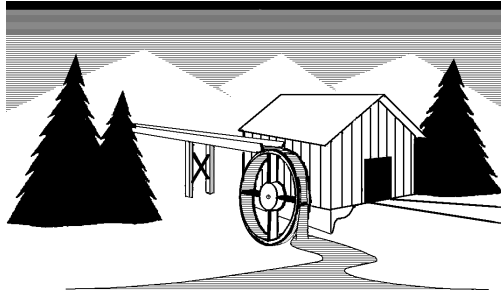

Music Systems

Ikemo - C

MTM Center Channel Loudspeaker System

**A small loudspeaker featuring the
North D25-06S and dual Vifa P13WH-00-08
in an EBS vented box.**

Woodworker's Kit Contents:

The woodworker's kit portion of this loudspeaker system was shipped in one carton.

This carton contains:

- (1) Instruction package.
 - Cabinet Assembly Manual
 - Response Curves
 - North Creek *Cabinet Handbook*
 - North Creek Wiring Guide

- (2) 1 oz. Rolls of Dacron stuffing.
- (1) Tube of "Liquid Nails" adhesive.
- (1) 2" x 3" Flared Port tubes.
- (20) Straws.

- (1) Roll of gasket tape.
- (8) Mushroom grille fasteners.
- (12) #6-1" black screws.
- (4) back cup screws.
- (1) Single Wired Back Cup with Gold Plated Binding Posts.

- (1) Assembled woofer crossover network.
- (1) Assembled tweeter crossover network.
- (1) Jumper wire, red on one end and black on the other.

- (1) North D25-06S Tweeter, shielded.
- (2) Vifa P13WH Woofers, shielded.

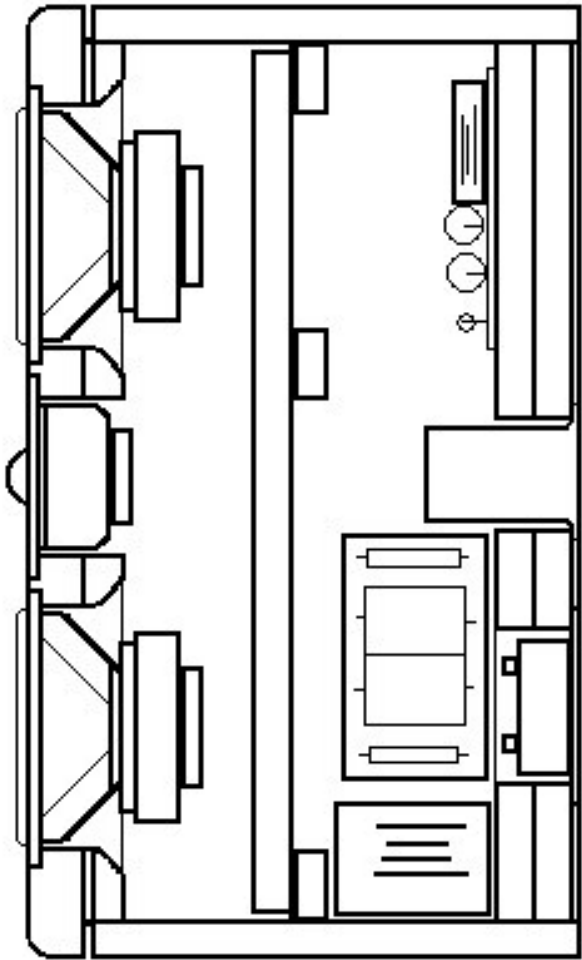

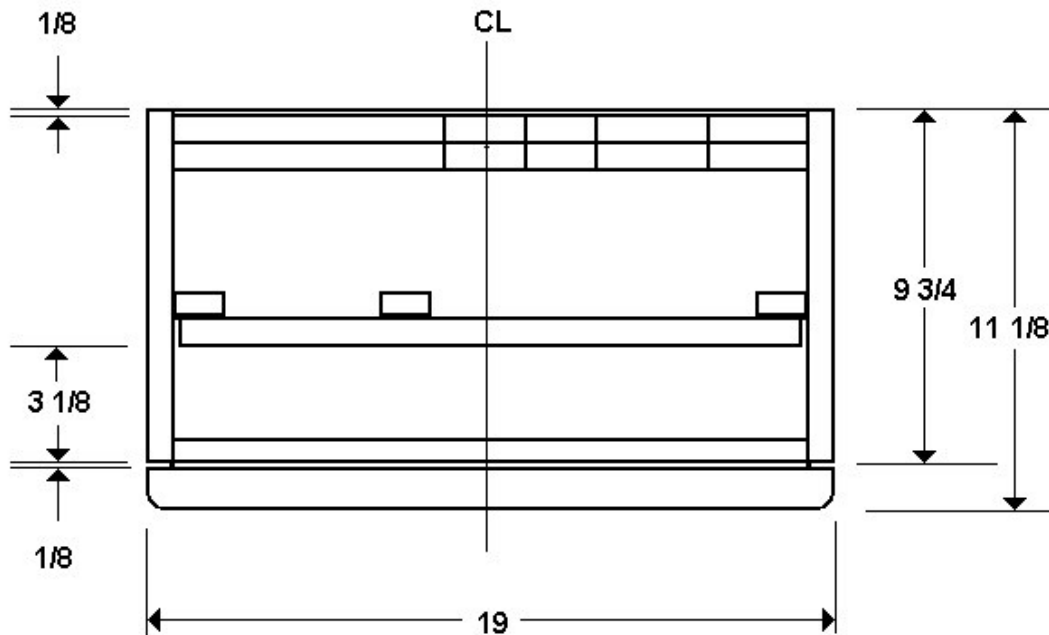

An overall dimensioned side view. Note that the back panel is inset 1/8", whilst the fascia is outset 1/8". This is purely cosmetic; one may eliminate both without affecting the internal box dimensions.

Additionally, the fascia is 1 1/4" MDF. This was made with one layer of 3/4" and one layer of 1/2" MDF, glued together with Titebond. One may use two layers of 3/4" if this is more convenient, as this is also cosmetic and will not affect the system performance.

Top and bottom panels: two pieces; 3/4" MDF, 9 3/4" x 19"

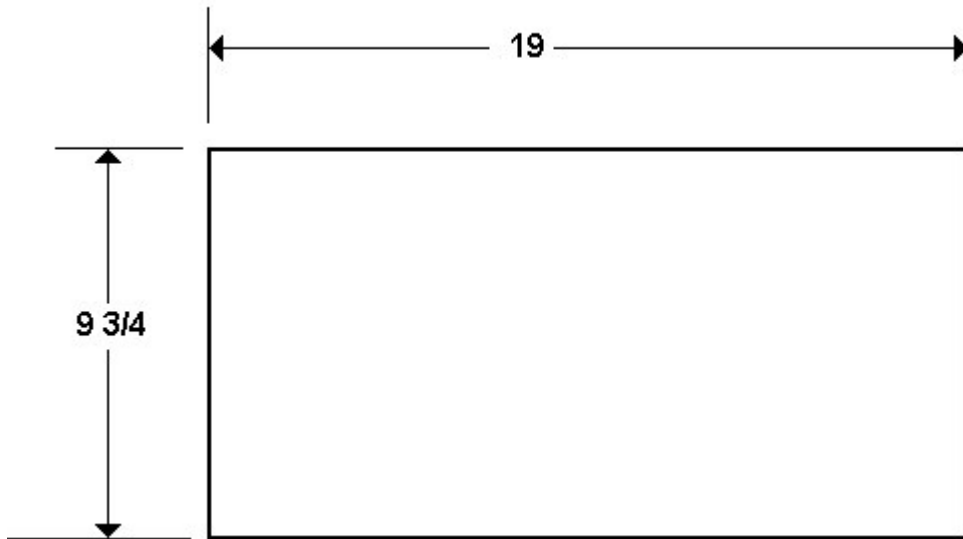

Side panels: 2 pieces, 3/4" MDF, 9 3/4" x 6"

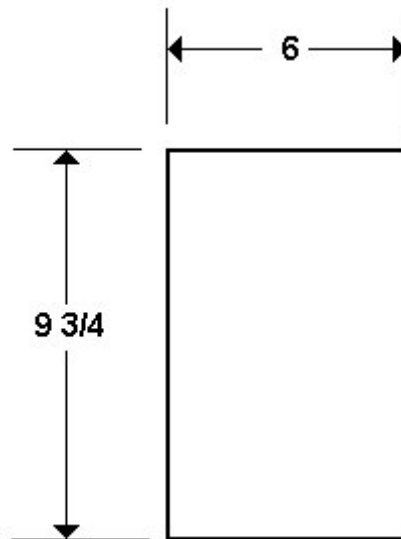

Back, Inner Front Panels:

1 pieces 3/4" MDF 6" x 17 1/2"

2 pieces 3/4" Birch Plywood 6" x 17 1/2"

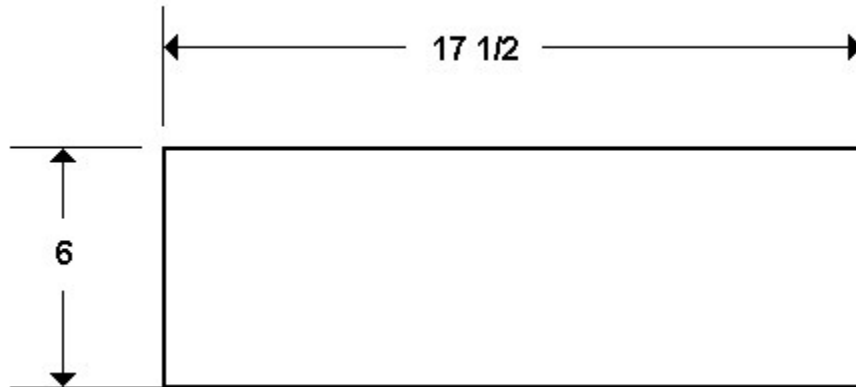

Fascia: 1 piece 1 1/4" or 1 1/2" MDF (may be a lamination); 7 1/2" x 19"

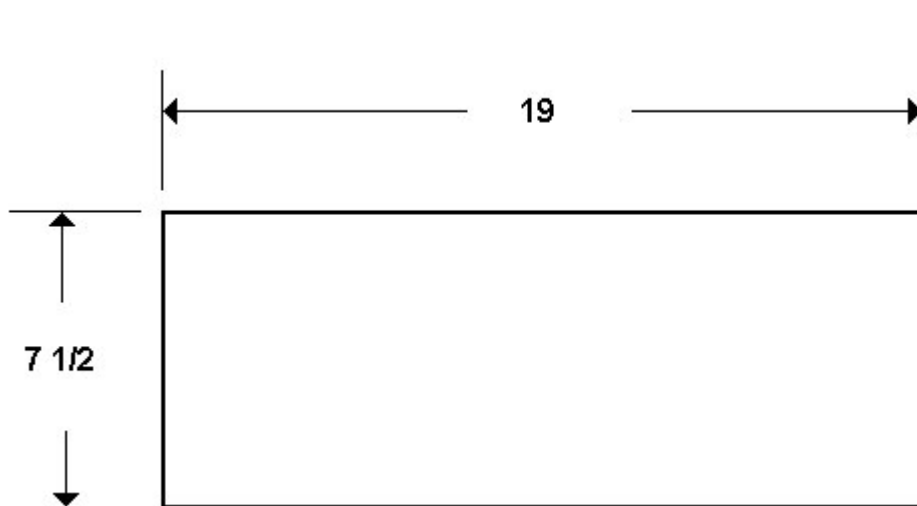

Braces:

3/4" birch plywood,
2 pieces 1 1/4" x 17"
3 pieces 1 1/4" x 5 1/2"

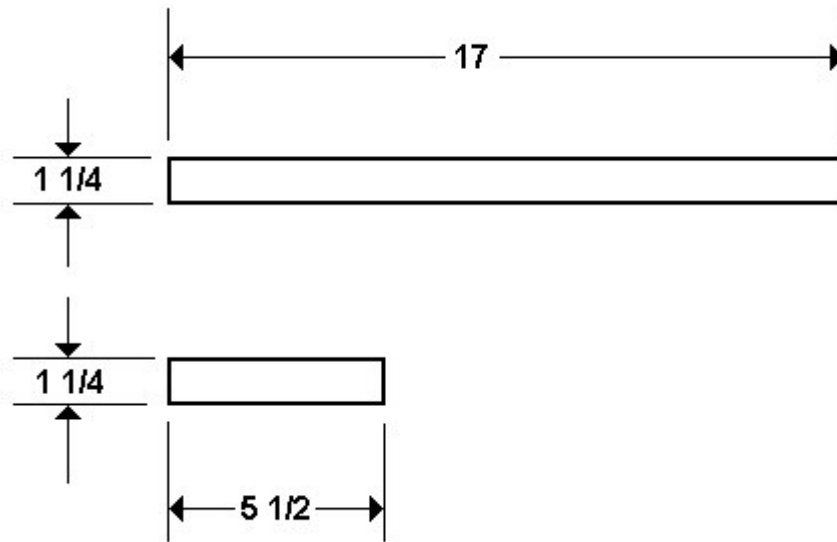

Back Panel Detail:

This panel is composed of one layer of MDF and one layer of birch plywood, laminated with hard glue such as Titebond.

The vent through hole and binding post cup through hole are cut through both panels.

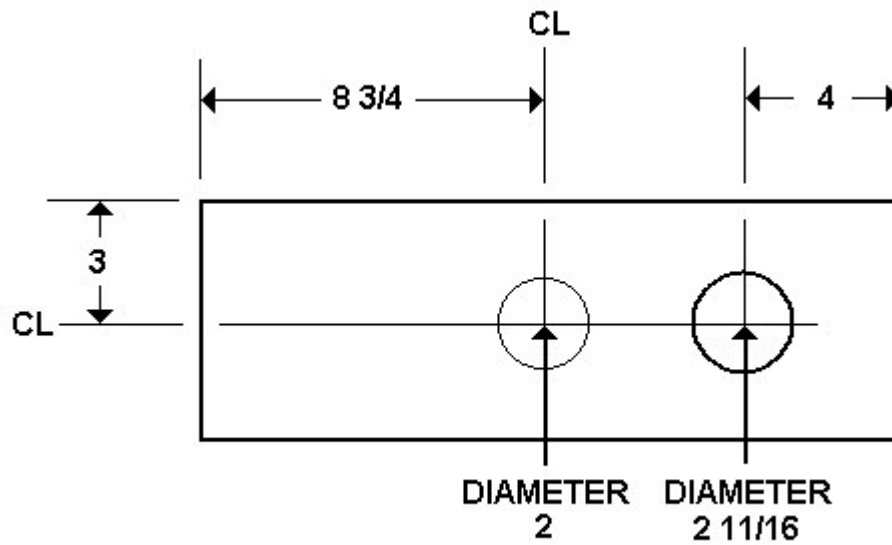

Inner Front Detail:

This panel is machined from 3/4" birch plywood.

After machining, the inside edge of the woofer cut out should be flared by a 1/2" diameter to 1" diameter roundover bit (the larger the diameter of this roundover, the better). The roundover should then be sanded smooth.

Both the woofer and tweeter through holes should be sealed with a very thin layer of hard glue, to prevent any air leak due to the porosity of the plywood.

Note that the through hole for both the woofer and tweeter are the same diameter as the matching openings in the Fascia. All of these panels should be machined with the same setting on a router circle cutter.

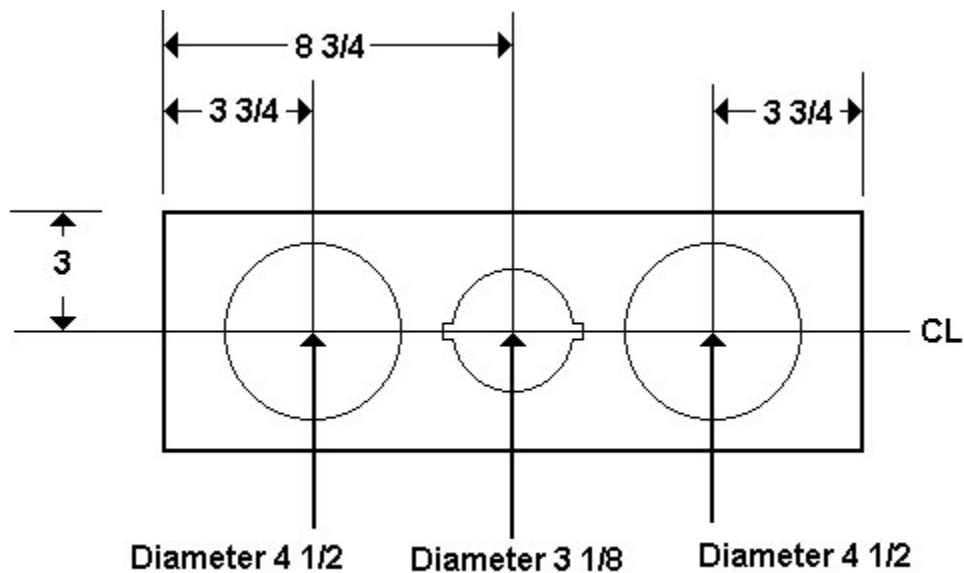

Fascia Detail:

This panel may be either 1 1/4" MDF or 1 1/2" MDF. It may be constructed of a single layer, two layers of 3/4" material, or a layer of 3/4" and a layer of 1/2". If using two layers, the adhesive should be a hard glue such as Titebond.

When machining the woofer and tweeter countersinks, measure carefully to be absolutely certain they are the correct diameter. The diameter we specify is actually very slightly larger than the flange driver flange diameters, to account for the thickness of any paint or surface finish.

Woofer and tweeter mounting holes should be drilled at this point.

The front edge of the fascia is rounded over with a minimum 3/4" diameter, maximum 1 1/4" diameter, roundover bit. If one chooses to veneer the front, roundover the side edges and leave the top and bottom square.

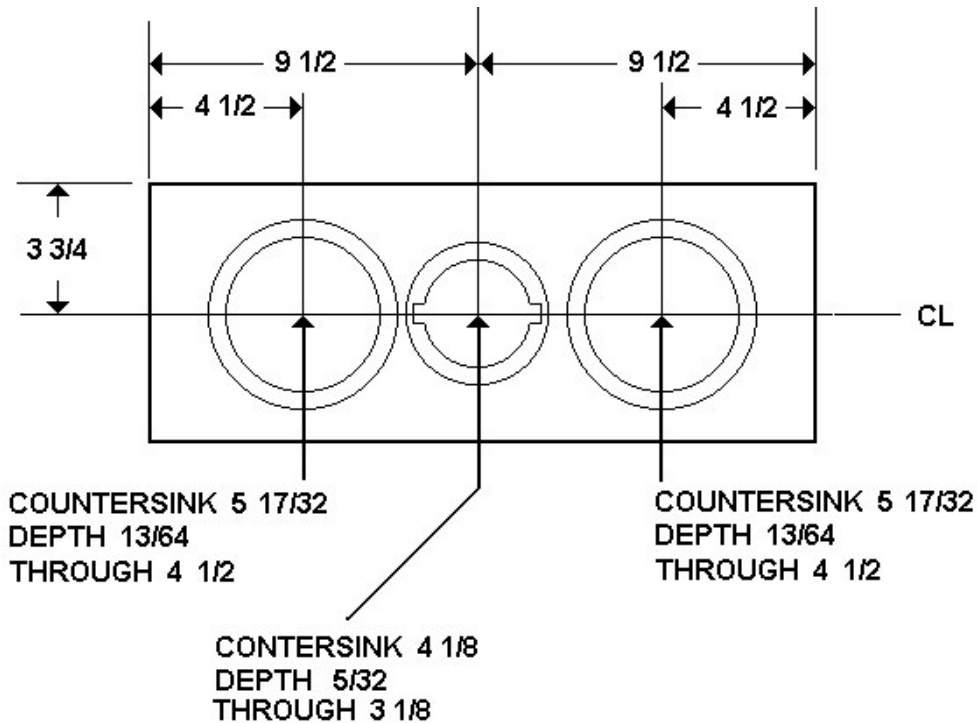

Assembly order: Brace on Top and Bottom, let dry; Side + top + back; inner front; side, bottom, cross-braces. It is easiest to attach the three cross-braces with pinch clamps. It is assumed the Fascia is finished separately and attached last.

Note the brace is offset $3 \frac{1}{8}$ " from the front edge of the top and side panels. This is $3 \frac{1}{4}$ " from the projecting edge of the "inner front".

Note that the back panel is inset $\frac{1}{8}$ ", whilst the fascia is outset $\frac{1}{8}$ ". This is purely cosmetic; one may eliminate both without affecting the internal box dimensions.

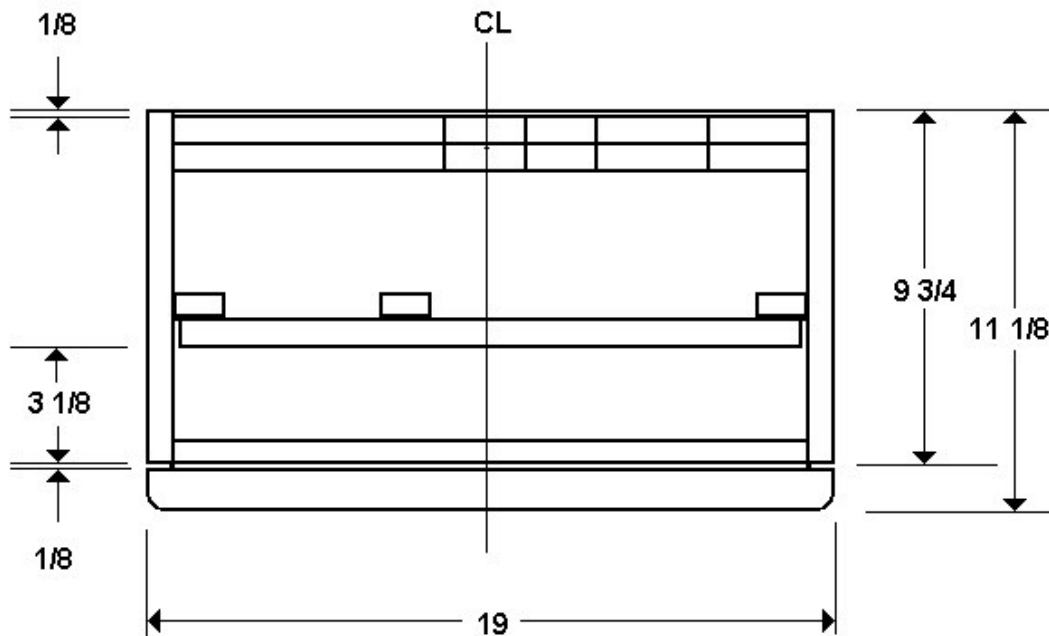

Port Tube, Crossover and Driver installation:

The cabinet is pretty tight, but everything fits together smoothly.

Without permanently attaching anything, the crossover boards must be inserted into the speaker cabinet.

- 1) The tweeter crossover is installed through the right woofer opening, rotated under the cross brace, and glued to the left back of the cabinet. Allow several hours or overnight to dry.
- 2) The woofer board and large loose woofer inductor is then installed through the right woofer cut out and rotated until the board lies flat on the bottom of the cabinet and the large inductor is against the right side panel. Glue the inductor on two corners and one face such that three surfaces are in contact with the cabinet. Glue the board to the cabinet bottom. Allow several hours or overnight to dry.
- 3) Feed the heat-shrunked Red, Black, White and Blue crossover input wires through the binding post cup opening. Turn the cabinet on its face. Attach the crossover input wires to the color coded posts on the cup (red = woofer (+) to Red Post; black = woofer (-) to Black Post; white = tweeter (+) to Red Post; blue = tweeter (-) to Black Post). The binding post cup is screwed to the cabinet.
- 4) Port Tube: The Port Tube should be cut to 3" overall length. Cut the straws into 2" lengths. Fill each port tube with as many straws as it will accept. The straws will begin to go out of round and into a hexagonal shape. It is VERY IMPORTANT that the port tube be filled with straws. The port tube is also installed by drilling four holes through the flat section of the port flange, slitting gasket tape in half the long way and adhering it to the rear of the flange, and inserting into the cabinet back, drilling pilot holes at an angle for the screws, and screwing in the port.
- 5) The cabinet is then returned to its back, the woofer and tweeter wires pulled through their respective driver openings. Push half of the stuffing behind each woofer. Be careful not to cover the end of the port tube with stuffing.

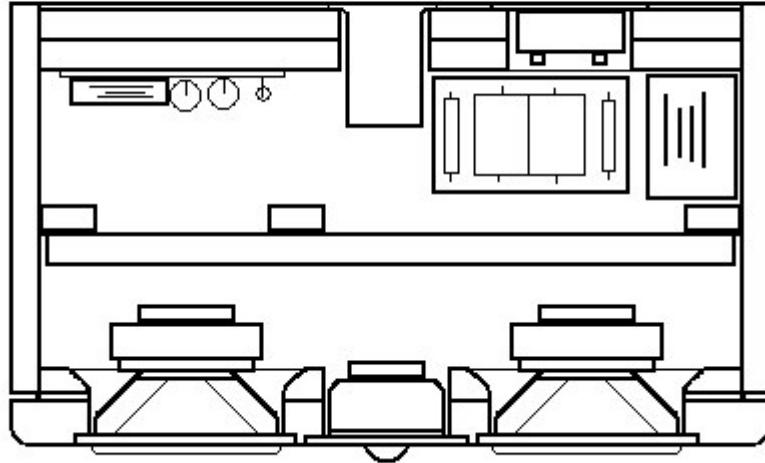

6) Adhere gasket tape to the woofer and tweeter countersinks, and trim off excess. Puncture through the gasket tape to mark the mounting screw positions.

7) The white (+) and blue (-) leads are attached to the tweeter, red (+) from the crossover board and black (-) from the jumper to one woofer, and the black (-) from the crossover board and red (+) to the other woofer. All drivers are mounted with #6 screws.

Optimum horizontal placement is on an 8" to 14" stand below the video screen, or resting on top of a projection television. Even though the drives are shielded, there is a small amount of stray field which may affect a CRT screen. The rear of the cabinet should be no closer than six inches from the rear wall, and may be as far as 40 inches out. If used on a bookshelf, the tweeters should be just above ear level.

For MTM main channel applications, optimum placement is vertical on 24" stands or horizontal on 36" stands. Bookshelf placement is horizontal just above ear level.

North Creek Music Systems

PO Box 1120
Old Forge NY 13420

www.NorthCreekMusic.com